

Design and prototype development of a harvesting machine mower for poppy (*Papaver somniferum L.*) plant

Orhan Güngör,¹ İbrahim Akıncı²

¹Department of Computer Technologies, Gölhisar Vocational School, Burdur Mehmet Akif Ersoy University, Gölhisar, Burdur;

²Department of Agricultural Machinery and Technologies Engineering, Faculty of Agriculture, Akdeniz University, Kepez, Antalya, Turkey

Abstract

In this study, a capsule-oriented prototype machine for the mechanical harvesting of poppy (*Papaver somniferum L.*) was developed, and its design characteristics and harvesting performance were evaluated. In Turkey, poppy cultivation is predominantly carried out on small-scale plots, and harvesting operations are generally performed manually, resulting in increased labor requirements and considerable crop losses. The prototype harvesting system was assessed in terms of harvesting efficiency and capsule loss under varying plant morphological characteristics. During the design process, the physico-mechanical properties of the poppy plant were determined, and the cutting blade configuration and motor selection were optimized accordingly. The harvesting performance of the machine was further analyzed under different plant heights and capsule numbers through experiments conducted under both laboratory and field conditions. Based on tests performed on 360 plant samples under laboratory and field conditions, the system achieved a harvesting efficiency of 92%, with capsule losses remaining below 8%. The circular cutting mechanism was found to require lower cutting force and to operate more efficiently than the vertical cutting system. In addition, the AC and DC motor systems integrated into the machine improved the plant conveying and capsule cutting processes by enabling variable speed and directional control. The results demonstrate that the developed prototype machine performs successfully in terms of both operational efficiency and harvesting quality. Furthermore, its applicability to larger-scale operations could be enhanced in the future through the integration of automatic feeding systems. These findings indicate that the developed cutting and brush-based conveying mechanism can reduce capsule loss more effectively than conventional single-point cutting mechanisms reported in previous studies.

Key words: agricultural mechanization; mechanical harvesting; poppy (*Papaver somniferum L.*); prototype machine.

Correspondence: Orhan Güngör, Department of Computer Technologies, Gölhisar Vocational School, Burdur Mehmet Akif Ersoy University, 15600, Gölhisar, Burdur, Turkey. E-mail: orhangungor@mehmetakif.edu.tr

Introduction

Poppy (*Papaver somniferum L.*) is an annual crop plant belonging to the Papaveraceae family with high economic and pharmaceutical value. In addition to being one of the basic raw materials of the pharmaceutical industry thanks to its alkaloids such as morphine, codeine and tebain, this plant draws attention with the use of oils obtained from its seeds in many industries such as food, cosmetics and biodiesel (Yücelşengün *et al.*, 2020; Cesur *et al.*, 2021). It has also been determined that poppy seeds have high antioxidant capacity (Şahin and Bursal, 2023). Turkey has accumulated significant experiences in terms of both legal regulations and agricultural practices in poppy cultivation and opium production in the historical process and has been recognized by the United Nations as one of the legal producing countries (Başlamışlı, 2021). In this context, Turkey maintains its leadership in this field with 64% of the world's poppy cultivation area (TMO, 2019).

Poppy production is a process that needs to be optimized not only in terms of quantity but also quality. Morphine and similar alkaloid contents are directly related to genetic variations, climatic

factors and agricultural management practices (Hope *et al.*, 2020; Krošlák *et al.*, 2017; György *et al.*, 2022). Therefore, the harvesting process is as important as the cultivation of the poppy plant. Especially in terms of alkaloid contents, the timing, method and application of harvesting play a critical role in terms of plant yield and substance loss (Yanardağ *et al.*, 2024).

Poppy harvesting remains largely manual, leading to high labour demand and significant capsule losses due to premature detachment. (Hacıyusufoğlu, 2013). On the other hand, since poppy is usually grown in small plots, there are incompatibilities in the use of large-scale mechanized harvesting machines. Variability in plant height and irregularities in land structure negatively affect machine efficiency (Kadioğlu, 2007). Nevertheless, special adapters and modern harvesting machines developed for poppy harvesting in European countries reduce labor costs and increase efficiency in capsule harvesting (Németh, 1998; Özarlan *et al.*, 2018).

One of the important advantages of mechanical harvesting systems is the even and uniform separation of ripe capsules from their stems (Sproll *et al.*, 2006; Yamaguchi *et al.*, 2010). However, some

mechanical systems also mix capsule fragments and stalk remnants into the content during the seed sorting stage, which can cause quality control problems, especially in pharmaceutical production (Földesi, 1992).

In this context, the development of capsule-oriented, simplified but efficient systems for poppy harvesting is a priority need, especially for countries like Turkey where small production plots are common. Özarlan *et al.* (2018) developed a prototype machine capable of harvesting poppy plants by separating the capsule from the stem, which was designed for domestic production and intended for medium-sized agricultural fields. This machine was evaluated in terms of mowing quality, stem-capsule separation and mechanical compatibility, and positioned as a step that will contribute to the widespread mechanization of poppy agriculture. Since the poppy plant has a more fragile and sensitive morphological structure, applying an optimization approach similar to the one proposed by Qin *et al.* (2020) for the corn harvesting mechanism may potentially result in capsule damage and material loss. Therefore, a poppy-specific system design and optimization strategy is required rather than directly adapting mechanisms developed for other crops. Existing systems lack capsule alignment, cutting-height control and transport stability, leading to increased capsule loss. The main objective of this study is to present the design and production process of a system for capsule harvesting only, which is suitable for the mechanical harvesting difficulties encountered in poppy production in Turkey. The prototype developed for this purpose simplifies the harvesting process, reduces the need for labor and offers a technical solution to the producer. The findings obtained can contribute to both national agricultural policies and modern agricultural mechanization practices. To the best of the authors' knowledge, the developed prototype is the first poppy-harvesting concept that integrates a brush-based transportation system, a pulling-brush mechanism, and a three-point cutting process in a single operational structure.

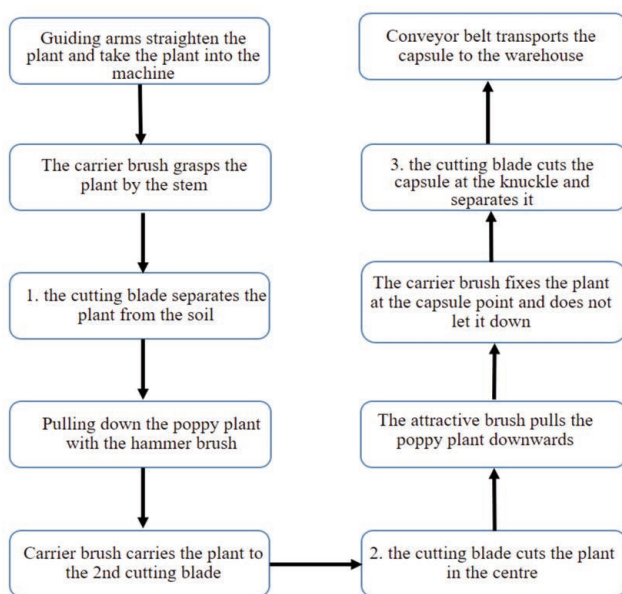

Figure 1. Workflow chart of the prototype machine.

Materials and Methods

In contrast to previous designs, the developed prototype machine was specifically engineered to align and position each plant at a uniform cutting height, thereby minimizing foreign material contamination and capsule losses during harvesting. This feature is particularly critical for capsule-oriented harvesting systems. The operational flowchart of the prototype machine is presented in Figure 1, while the closed schematic solid model of the developed machine is shown in Figure 2.

Brush designs

Before developing the prototype machine, the physico-mechanical properties of the poppy plant the researchers determined in the field (Güngör and Akinci, 2024). Based on the physico-mechanical properties identified, the height and length of the prototype machine, as the researchers as the positions of the carrier brush, pulling brush, and cutting blades, the researchers determined. The solid model views of the designed carrier brush and pulling brush are shown in Figure 3.

The rotary motion of the brushes was driven by DC motors operating at a constant speed of 30 rpm. The carrier and pulling brushes were dimensioned according to the average plant height previously measured in field conditions (115 cm) (Güngör, 2023). The height of the carrier brush of the prototype machine was designed by taking this value as reference.

Cutting blades

The mowing unit is equipped with 3 cutting blades. The position of the cutting blades used for the three-point cutting process is such that all plant heights of different sizes are brought to the same height until they reach the end of the prototype mowing unit. The task of the 1st blade in the prototype machine is to separate the

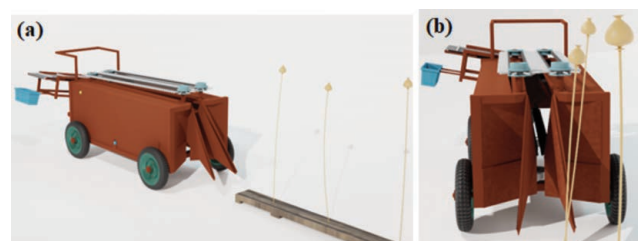

Figure 2. Prototype machine closed schematic solid model. a) Perspective view. b) Front view.

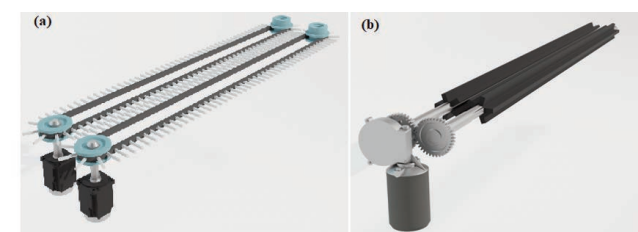

Figure 3. Brush designs. a) Carrier brush. b) Pulling brush.

plant from the soil. Therefore, this blade is mounted at the point where the plant enters the prototype machine (Figure 4).

The task of the 2nd blade is to shorten very branched and tall plants, both to separate the branched structure from each other and to shorten the tall plants, so it is mounted under the pulling brush (Figure 5).

The task of the 3rd blade is to separate the poppy capsule from the poppy stalk at the knuckle point, which is considered the most efficient point for harvesting. The 3rd cutting blade is placed just below the carrier brush as shown in Figure 6. In this way, the cutting process was realized from the knuckle point at the bottom of the capsule.

Cutting blade motors the researchers supplied with 220 V AC voltage. Circular cutting method was used for the cutting process. The reason for this is to ensure that the plant stem can continue along the carrier brush after the cutting process without getting stuck. The optimum cutting blade rotation speed was experimentally determined as 7700 rpm based on comparative trials conducted at different speeds during the author’s doctoral research, where this value resulted in the lowest capsule loss and vibration, ensuring a clean and stable cutting operation (Güngör, 2023).

The vertical shear values of white poppy plants used in this study were previously reported by Güngör and Akıncı (2025). The vertical and circular cutting data corresponding to the optimum blade speed of 7700 rpm are presented in Table 1. Eq. (1) was used to calculate vertical cutting power, and Eq. (2) was used to calculate circular cutting power. For all circular cutting calculations, a reference cutting duration of 1 sec was assumed.

$$F_{\text{vertical}} = F_{\text{vertical}} \cdot V \tag{Eq. 1}$$

$$P_{\text{circular}} = F_{\text{circular}} \cdot \frac{2\pi r}{t} \tag{Eq. 2}$$

where P_{vertical} is the vertical cutting power (W); vertical is the vertical shear force (N); V is the cutting speed (m/s); P_{circular} is the circular cutting power (W); circular is the circular shear force (N); r is the disk radius (m) and t is the time (s).

Eq. (3) was used to determine the proportionality constant (k) based on the measured vertical and circular cutting forces.

$$F_{\text{circular}} = k \cdot F_{\text{vertical}} \tag{Eq. 3}$$

Where circular is the circular shear force (N); vertical is the vertical shear force (N); and k is the constant by the researchers forces.



Figure 4. Cutting blade layout.



Figure 5. Cutting blade placement.

Table 1. Circular and vertical shear data.

	Vertical cutting	Circular cutting	k constant	k constant at shear
Rotation	-	7700 rpm	-	-
Advance speed	0.0000833 m/s	20 m/s	-	-
Cutting force (top)	42 N	3.45 N	0.08	0.005
Cutting force (medium)	72.5 N	5.18 N	0.07	0.027
Cutting force (bottom)	129 N	6.48 N	0.05	0.025
Cutting power (top)	0.0035 W	160 W	3980	248
Cutting power (medium)	0.0060 W	240 W	2718	1019
Cutting power (bottom)	0.01075 W	300 W	2572	1286

The above-mentioned carrier brush, pulling brush and cutting process from 3 different points stand out as innovative features unlike previous designs.

Guiding arms and conveyor belt

In front of the prototype machine, the researchers designed deflector arms to straighten the tilted plants and guide them between the conveyor brushes, and behind the machine, a conveyor belt was designed to transport them to the warehouse after harvesting (Figure 7). Since the prototype machine was designed for single-row harvesting, a 5 cm stalk-entry gap was provided after the guiding arms. The conveyor belt motor was powered by a 12 V DC supply. The distance between the conveyor belt steps, which transport the capsules to the storage unit, was set at 30 cm. The technical drawing of the designed machine is presented in Figure 8, the solid model is shown in Figure 9, and the manufactured prototype is illustrated in Figure 10.

The prototype machine consisted of three independently driven rotary components operating at different speeds, namely the carrier brush (26 rpm), the pulling brush (30 rpm), and the carrier belt (20 rpm). Cutting force measurements were obtained using a TST Mares tensile-compression testing device, while the rotational speed of the circular cutting blades was measured using a digital tachometer. The tachometer had an effective measurement distance range of 50–500 mm and a sampling time of 0.5 s. All rotational speed and force measurements were performed under identical mechanical alignment and operating conditions to ensure repeatability and measurement accuracy.

A total of 360 capsule samples were used in the study. The plants were classified into three stem-height categories (86–105 cm, 106–125 cm, and 126–145 cm) and five capsule-number groups (1, 2, 3, 4+ capsules, and control). For each capsule-number group, 24 capsule samples ($n=24$) were tested within each height category, resulting in 120 samples per height group ($n=120$) under both laboratory and field conditions. The experiments were performed using *Papaver somniferum* L. cv. Ofis-2 (white). Prior to testing, the mean moisture content of the upper stem region and lower stem region was determined as 14.52% and 9.42%, respec-

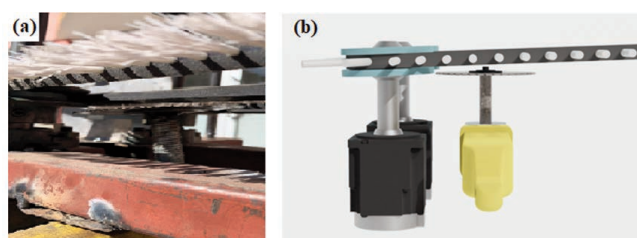

Figure 6. Cutter blade layout: realized assembly (a) and solid model view (b).

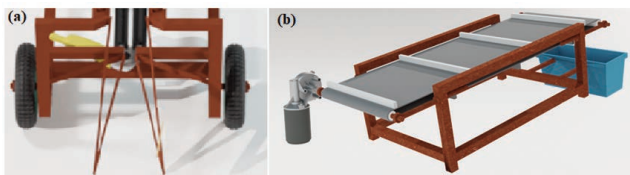

Figure 7. Additional designs: guiding arms (a) and conveyor belt (b).

tively (wet basis). The harvesting performance tests were carried out independently under controlled laboratory conditions and natural field conditions. A completely randomized design was used based on stem-height and capsule-number groupings. Cutting performance was evaluated according to internode cutting length, capsule retention, and capsule loss rate. Statistical analysis was performed using one-way analysis of variance (ANOVA), and the differences among group means were evaluated using Duncan's Multiple Range Test (DMRT). The level of significance was interpreted at $p>0.01$, and letter groupings (a, b, c) were used to indicate non-significant differences between means. To ensure transparent comparison, all numerical results were presented as mean \pm SD. Laboratory and field datasets were evaluated independently to prevent interaction or bias between experimental conditions.

Results

Plants of different height and number of capsules the researchers used in the trials. The comparisons were based on $n=24$ replications for each capsule-number group. Harvest success was evaluated on the basis of capsule internode cutting rate and loss rate. Laboratory and field conditions the researchers designed separately and prototype performance was tested for each. Different

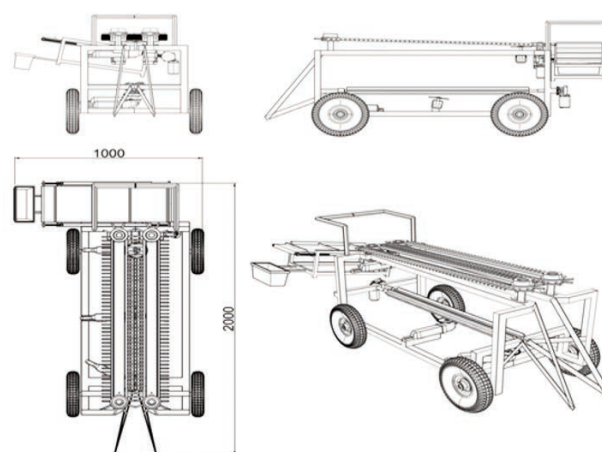

Figure 8. Technical drawing of the prototype machine showing the main structural components and functional layout.

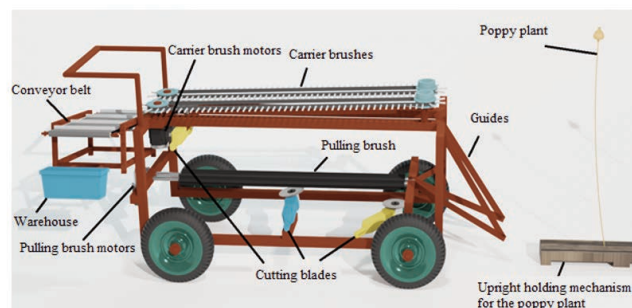

Figure 9. Solid model side view of the prototype poppy harvesting machine showing the carrier and pulling brush systems, cutting blades, and conveying mechanism.

height and number of capsules the researchers based on the study of GÜNGÖR (2023). Plants with different number of capsules in the harvesting process are shown in Figure 11. A visual of the harvesting process in the field is given in Figure 12.

The appearance of the plant stem and capsule at the end of the harvesting process is given in Figure 13; as seen, the plant stem is divided into 3 parts. This provides an advantage over other harvesting methods as it facilitates the incorporation of the plant stem into the soil as fertilizer. A sample of the harvest results is given in Table 2.

In the experimental design, poppy plant height was taken by the researchers 86 cm and 105 cm. Plants with 1,2,3,4 or more capsules and witness plot treatment are shown in separate columns. The most efficient point of harvesting is the node under the capsule. Five different sub-node length classifications the researcher made as 0-25, 26-50, 51-75, 51-50, 76-100 and over 100 and a success class was formed. In addition, the amount of loss during the harvesting process was also classified in the table. It has been stated that the yield of morphine and its derivatives obtained from poppy capsule decreases as the length of the stalk under the internode increases (Güngör, 2023).

As presented in Table 2, the highest number of capsules harvested was obtained in the 0-25 mm internode cutting group, indicating that cutting closer to the capsule significantly improves harvesting success. When evaluated based on capsule count per plant, the most successful outcome was obtained from single-capsule plants, which showed a mean loss rate of 7.69% , whereas the highest harvesting loss occurred in plants with two capsules. Statistical analysis confirmed that harvesting losses increased significantly with capsule number (ANOVA, $p < 0.01$). Additionally,

an increasing trend was observed in stem length as the capsule number increased. To further illustrate the relationship between internode cutting length and harvesting performance, a comparative distribution chart is presented in Figure 14. The graphical trend clearly demonstrates that the 0-25 mm cutting length consistently yielded the highest harvesting performance across all capsule-number groups, confirming that low-position cutting is criti-

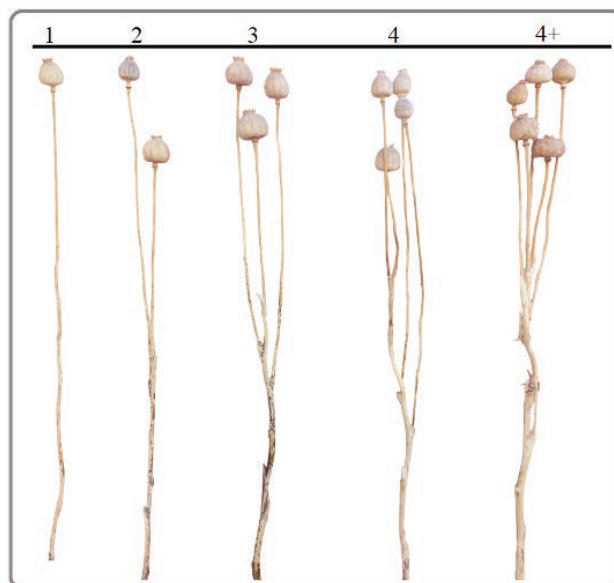

Figure 11. Poppy plants with different capsule numbers.



Figure 10. Side view of the developed poppy harvesting prototype showing the carrier and pulling brush systems, circular cutting blades, and capsule collection unit.



Figure 12. Harvesting process in the field.

Table 2. Prototype machine harvesting trial result.

Poppy size (cm)	86-105				
Number of capsules per plant (number)	1	2	3	4+	Witness parcel
Under-node stalk cutting length					
0-25 mm ^a	22	21	15	16	21
26-50 mm ^b	0	1	3	5	2
51-75 mm ^b	1	0	2	1	1
76-100 mm ^b	0	1	2	1	0
100+ mm ^b	1	1	2	1	0
Amount of loss (quantity)	2	4	3	3	2
Loss rate (%)	7.69	14.28	11.11	11.11	7.69

^{a,b}The difference by the researchers means with the same letter is statistically insignificant ($p > 0.01$); mean comparisons were interpreted using one-way ANOVA followed by Duncan's Multiple Range Test.

cal to minimizing capsule loss. Güngör (2023) also included the results of other experimental designs in his study. The results of the experimental designs are similar. It can be said that harvest success increases as the number of capsules decreases.

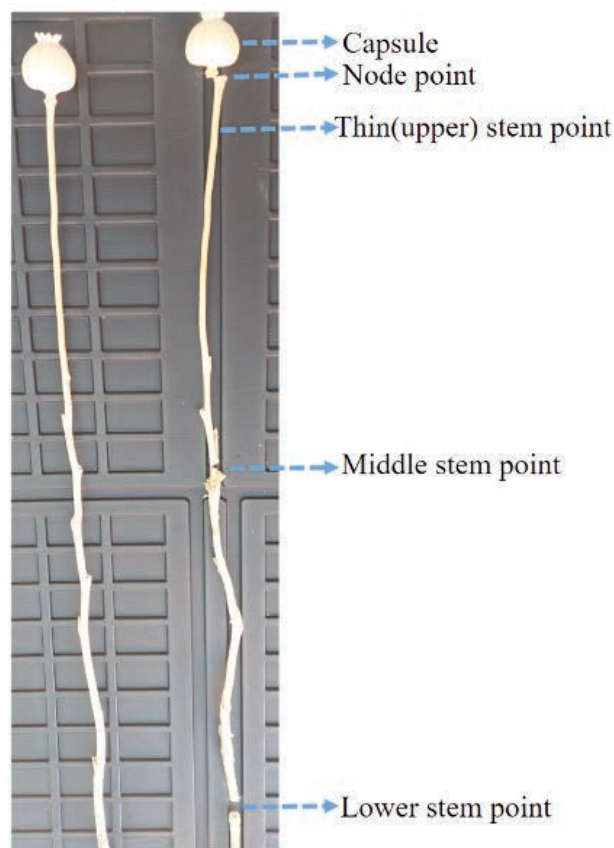

Figure 13. Cutting points of the poppy plant at the three blade stages, illustrating capsule detachment zones.

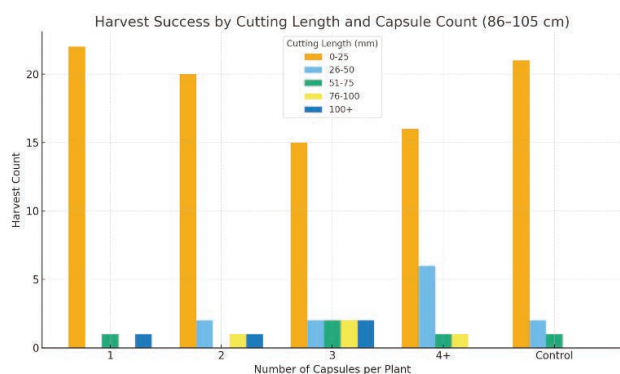

Figure 14. Distribution of harvested capsules according to internode cutting length (0-25, 26-50, 51-75, 76-100, and 100+ mm) for different capsule-number groups in the 86-105 cm height category.

Discussion

The results obtained from the prototype harvesting machine clearly demonstrate that capsule-oriented mechanisation is feasible for poppy cultivation under Turkish conditions. The highest harvesting success was achieved at 0-25 mm internode stem length, which is consistent with previous findings that capsule detachment close to the node reduces losses and preserves alkaloid content (Yanardağ *et al.*, 2024). This outcome highlights the importance of proper blade positioning and reinforces the significance of circular cutting systems. Circular cutting reduces shear concentration and maintains a more consistent cutting angle, resulting in fewer capsule detachments. This observation is consistent with the mechanistic findings reported by Özarşlan *et al.* (2018).

Compared with vertical cutting, the circular cutting method required less force and provided smoother separation, which agrees with the mechanical principles reported by Güngör and Akinci (2024) regarding the physico-mechanical properties of poppy stems. In addition, the use of AC and DC motors for brush and conveyor systems allowed flexible control of speed and direction, which optimised both capsule transport and cutting efficiency. This type of electronically controlled mechanism represents an innovation compared to earlier designs such as those by Özarşlan *et al.* (2018), where adaptability to variable plant height was more limited.

The experimental findings also suggest that plant morphology, particularly capsule number and stem height, significantly influences harvesting efficiency. The higher loss rates observed in plants with two or more capsules can be attributed to branching complexity, which disrupts the plant's alignment during feeding. The presence of a secondary capsule changes the entry angle of the stem, reducing brush stability and increasing the likelihood of capsule detachment during cutting. These results underline the necessity of further design adjustments, such as multi-row configurations or adaptive blade settings, to improve performance across different plant types.

Despite its promising performance, the current prototype has limitations. Manual propulsion reduces field-scale efficiency and restricts large-scale adoption. Moreover, the total working width is narrow, which limits capacity. Future improvements should focus on integrating automatic feeding systems, adjustable blade heights, and multi-row brush assemblies to enhance field applicability. Integrating tractor-mounted or PTO-assisted propulsion systems, together with autonomous feeding platforms and machine-vision-based capsule positioning modules, could significantly increase field capacity and improve capsule alignment during continuous harvesting. Overall, the prototype machine contributes an original approach to the mechanisation of poppy harvesting. By reducing labour requirements, minimising capsule losses, and ensuring cutting quality, the system addresses critical challenges in small-plot production systems. The study therefore provides a foundation for further engineering refinements and for scaling mechanised poppy harvesting to broader agricultural contexts.

Conclusions

In this study, an electronically controlled prototype machine was developed for mechanized harvesting of poppy plants. The pulling brushes convey the intercepted plants vertically toward the carrier brush mechanism. In the prototype, the circular cutting method, which is rarely used in harvesting machines, was used.

The speed of the motor to which the blade is connected was controlled. In addition, the cutting process was done at three different points. In most of today's harvesting machines, cutting is done from a single point. The three-stage cutting and brush system demonstrated effective capsule separation across varied plant structures. In this way, the calibration process and the harvesting process the researchers more successful. As a result, the number of circular cutting blades could be increased, improving material alignment and enhancing calibration efficiency. For the prototype machine, a stepped conveyor belt was designed to transport the harvested capsules to the warehouse. In the front part of the prototype, guiding arms the researchers made so that the tilted plants could be grasped by the carrier brushes. If the length of the conveyor brush and the pulling brush is increased, the distance by the researchers the guiding arms can also be increased since the harvesting sequence in row crop fields can be increased.

The prototype machine is manually operated by the user through push-assisted propulsion. Future development will involve integrating the mechanism with a tractor-mounted PTO-driven platform to enhance operational throughput, reduce labor dependency, and improve scalability for commercial use. Integration of row-detection-based autonomous navigation systems, similar to those described by Shi *et al.* (2023), may further improve alignment precision and enable full automation in future prototype versions.

References

- Başlamışlı M, 2021. [Abd'nin Türkiye'ye yönelik ambargo kararına ilişkin haşhaş sorunu yerine 1974 Kıbrıs krizini ön plana çıkarma girişimi]. [Article in Turkish]. *Asia Minor Stud* 9:695-712.
- Cesur C, Eryılmaz T, Uskutoğlu T, Doğan H, Şenkal B, Sezer S, 2021. [Haşhaş tohum (*Papaver somniferum* L.) Yağının biyodizel yakıt özelliklerinin belirlenmesi]. [Article in Turkish]. *Konya J Eng Sci* 9:797-808.
- Földesi D, 1992. Poppy. In L. Hornok (ed.), *Cultivation and processing of medical plants*. Budapest, Akadémiai Kiadó. pp. 119-128.
- Güngör O, 2023. [Haşhaş bitkisi için biçme düzeni parametrelerinin belirlenmesi ve elektronik kontrollü prototipinin geliştirilmesi-Determination of cutting unit parameters for poppy plant and development of an electronically controlled prototype]. [PhD Thesis in Turkish]. Graduate School of Natural and Applied Sciences, Akdeniz University.
- Güngör O, Akinci İ, 2024. Determination of some physico-mechanical properties and critical velocity of opium poppy plant (*Papaver somniferum* L.) 'Ofis 1' (blue). *J Tekirdag Agr Faculty* 21:1213-1221.
- Güngör O, Akinci İ, 2025. Investigation of selected physico-mechanical properties of the Office 2 (white) poppy plant. *J Agr Faculty Ege Uni* 62:381-390.
- György Z, Alam S, Priyanka P, Németh É, 2022. Genetic diversity and relationships of opium poppy accessions based on SSR markers. *Agriculture* 12:1343.
- Hacıyusufoğlu AF, 2013. [Laboratuvar koşullarında haşhaş kapsül toplama sisteminin geliştirilmesi-Development of a poppy capsule harvesting system under laboratory conditions]. [PhD Thesis in Turkish]. Graduate School of Natural and Applied Sciences, Adnan Menderes University.
- Hope E, Carins-Murphy M, Hudson C, Baxter L, Gracie A, 2020. Opium poppy capsule growth and alkaloid production is constrained by shade during early floral development. *Ann Appl Biol* 176:296-307.
- Kadioğlu Y, 2007) [Uşak'ta haşhaş tarımının coğrafi özellikleri]. [Article in Turkish]. *Doğu Coğrafya Dergisi* 12:165-186.
- Krošlák E, Maliar T, Nemeček P, Viskupičová J, Maliarová M, Havrlentová M, Kraic J, 2017. Antioxidant and proteinase inhibitory activities of selected poppy (*Papaver somniferum* L.) genotypes. *Chem Biodivers* 14:e1700176.
- Németh É, 1998. Raw material production: cultivation of poppy in the temperate zone. In J. Bernáth (Ed.), *Poppy: the genus Papaver*. Amsterdam, Harwood Academic Publishers. pp. 219-255.
- Özarlan C, Saraçoğlu T, Hacıyusufoğlu AF, 2018. [Haşhaş Hasat Makinası Geliştirilmesi]. [Article in Turkish]. *Bilge Int J Sci and Technol Res* 2:82-91.
- Qin J, Yin Y, Liu Z, Du Y, Wang G, Zhu Z, Li Z, 2020. Optimisation of maize picking mechanism by simulation analysis and high-speed video experiments. *Biosyst Eng* 189:84-98.
- Shi J, Bai Y, Diao Z, Zhou J, Yao X, Zhang B, 2023. Row detection-based navigation and guidance for agricultural robots and autonomous vehicles in row-crop fields: Methods and applications. *Agronomy* 13:1780.
- Sproll C, Perz R, Lachenmeier D, 2006. Optimized LC/MS/MS analysis of morphine and codeine in poppy seed and evaluation of their fate during food processing as a basis for risk analysis. *J Agric Food Chem* 54:5292-5298
- Şahin Y, 2023. [Haşhaş (*Papaver somniferum* L.) bitkisinin kimyasal içerik, antioksidan aktivite ve asetilkolinesteraz enzim inhibisyonu özelliklerinin belirlenmesi-Determination of chemical content, antioxidant activity, and acetylcholinesterase enzyme inhibition properties of poppy (*Papaver somniferum* L.) plant]. [Thesis in Turkish]. Graduate School of Natural and Applied Sciences, Muş Alparslan University.
- Toprak Mahsulleri Ofisi (TMO), 2019. [2018 yılı haşhaş sektör raporu -2018 poppy sector report]. [in Turkish]. General Directorate of the Turkish Grain Board. Available from: <https://www.tmo.gov.tr/Upload/Document/hashhassektorraporu2018.pdf>
- Yamaguchi K, Hayashida M, Hayakawa H, Nihira M, Ohno Y, 2010. Urinary morphine and codeine concentrations after ingestion of bean-jam buns decorated with poppy seeds. *Forensic Toxicol* 29:69-71.
- Yanardağ Y, Day S, Bayraktar N, 2024. Characterization of capsule morphologic properties and alkaloid contents of Turkish poppy genotypes within Ankara environmental conditions. *J Anim Plant Sci* 34:1031-1039.
- Yücelşengün İ, Yücel E, Öztürk B, Kiliç G, 2020. [Haşhaş (*Papaver somniferum*) çeşitlerinin tohum yağlarının yağ asidi kompozisyonu, toplam fenolik madde miktarı, antioksidan ve antimikrobiyal aktiviteleri]. [Article in Turkish]. *Gıda* 45:954-962.

Received: 24 September 2025; Accepted: 23 January 2026.

Contributions: Orhan Güngör, study conception, design, prototype development, data collection, analysis, interpretation, and manuscript drafting. İbrahim Akinci, supervision, methodological guidance, critical review, and contribution to manuscript editing. All authors read and approved the final version of the manuscript and agreed to be accountable for all aspects of the work.

Conflict of interest: the authors declare no competing interests.

Availability of data and materials: the datasets used and/or analyzed during the current study are available from the corresponding author on reasonable request.

Acknowledgements: this article is derived from the Doctoral Thesis of the first author.

Publisher's note: all claims expressed in this article are solely those of the authors and do not necessarily represent those of their affiliated organizations, or those of the publisher, the editors and the reviewers. Any product that may be evaluated in this article or claim that may be made by its manufacturer is not guaranteed or endorsed by the publisher.

This work is licensed under a Creative Commons Attribution-NonCommercial 4.0 International License (CC BY-NC 4.0).